



**SCHONBEK®**

**NEW ORLEANS 3648- \_\_ \_\_ S**



**T**HIS DESIGN IS THE PROPRIETARY TRADE DRESS/TRADemark OF SWAROVSKI LIGHTING, LTD.

4 Lights  
Diameter: 12"  
Body Length: 16-1/2"  
Hanging Weight: 4 lbs.



**SCHONBEK®**

MAX 60 W		110-120 V					

SCHONBEK® is a member of the Swarovski group.

All electrical components must be installed by a licensed electrician in accordance with the National Electric Code and the appropriate local electrical codes.

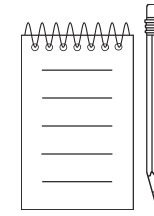
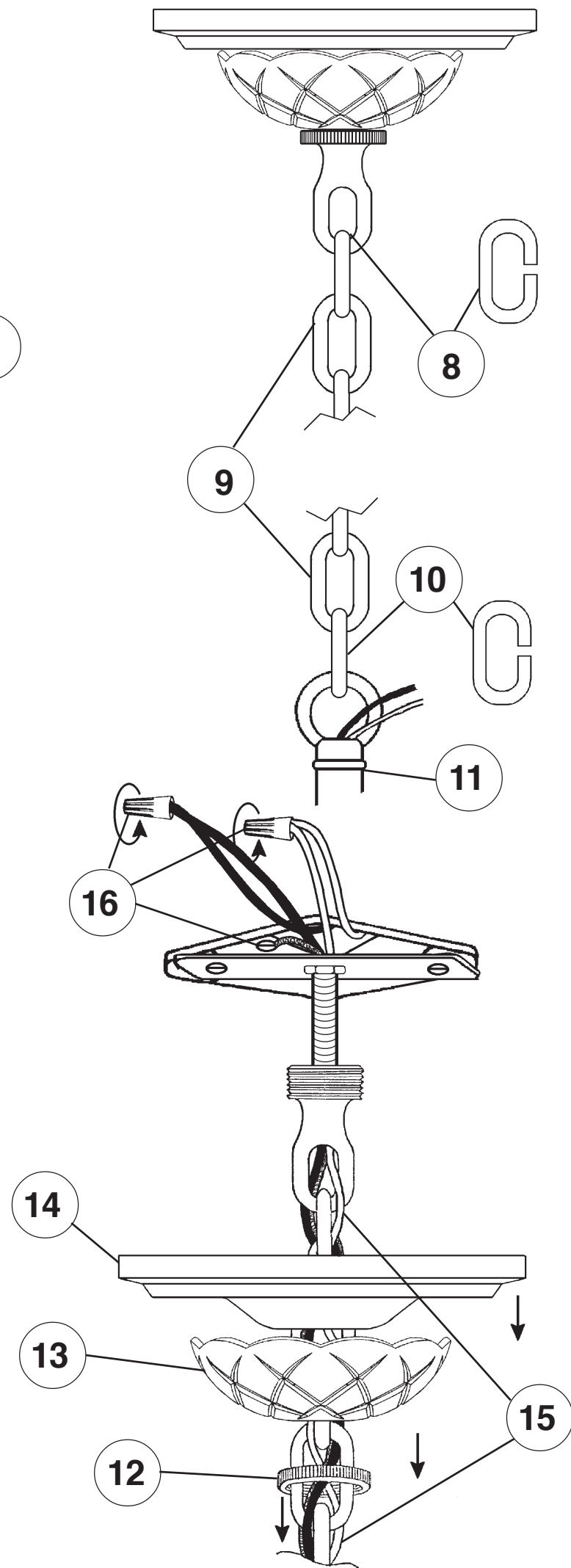
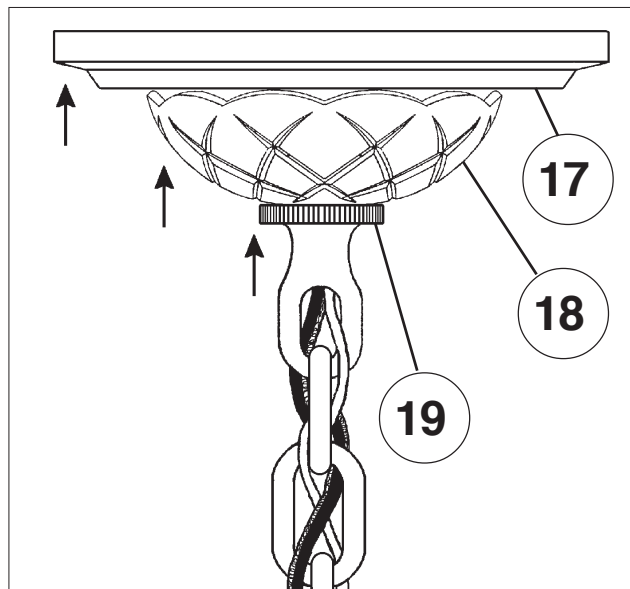
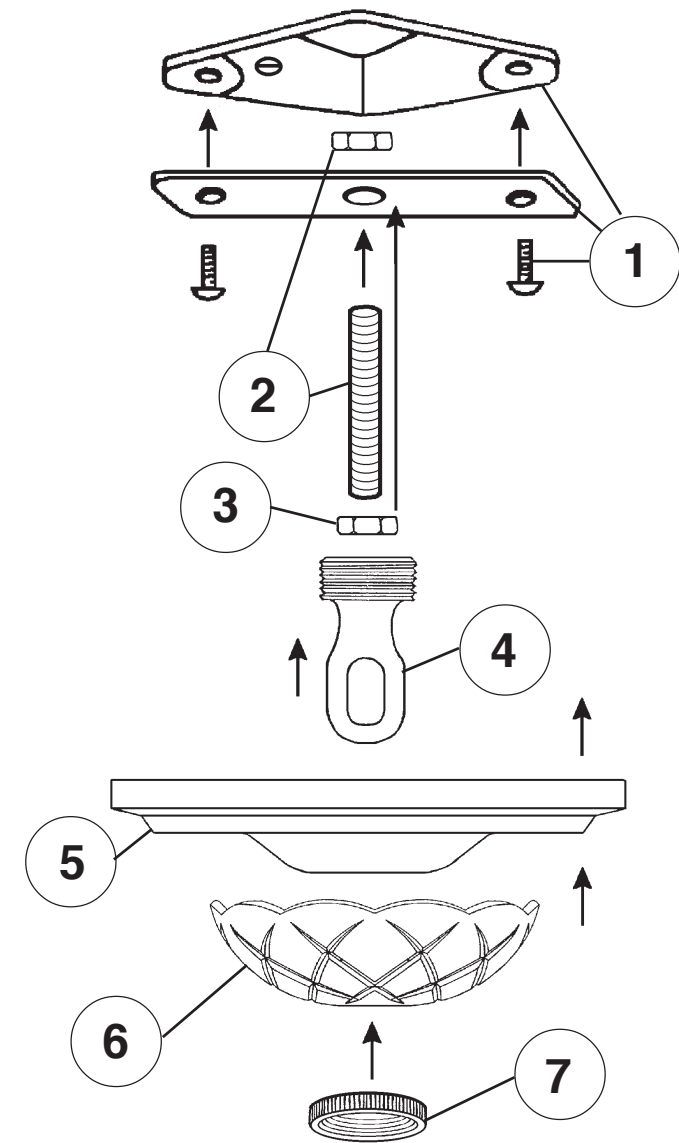



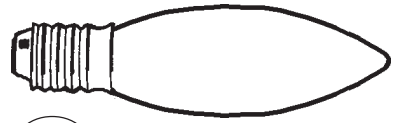

20

You will need 4 - B10  
25 Watts Recommended  
60 Watts Max

Install bulb and be sure  
to test fixture **BEFORE**  
trimming.

